

# IV211

## IVECO Daily 4x4

Dal 2009 – motore 2998 cc – 4 cilindri – con A/C

From 2011 – engine 2998 cc – 4 cylinders – with A/C

### Istruzioni di montaggio kit innesto elettromagnetico

- **Smontare maschera frontale**
- **Smontare paraurti anteriore**
- **Smontare proiettori**
- **Smontare viti di fissaggio radiatori**
- **Spostare in avanti il gruppo radiatori (non occorre staccare i tubi)**
- **Smontare ventola radiatore**
- **Sollevarre il veicolo mediante un adeguato ponte sollevatore**

### Electromagnetic clutch kit installation instructions

- **Disassemble the front mask**
- **Disassemble bumper**
- **Disassemble projectors**
- **Disassemble screws radiators**
- **Move forward radiator unit (is not necessary to disconnect the hoses)**
- **Disassemble radiator fan**
- **Raise the vehicle by means of a suitable lift bridge**

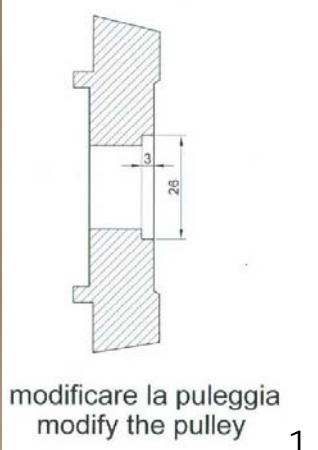
	 <p>modificare la puleggia modify the pulley</p>	<ul style="list-style-type: none"><li>- Smontare cinghia compressore A/C</li><li>- Smontare puleggia motore , modificarla come in foto 1 , poi rimontarla</li><li>- Sovrapporre la puleggia fornita e fissare il tutto col bullone fornito</li><li>- Rimontare cinghia compressore A/C</li><li>- <i>Disassemble the A/C compressor belt</i></li><li>- <i>Disassemble the motor pulley , amend it as in the picture 1 , then reassemble</i></li><li>- <i>Superimposing the provided pulley and secure all with the provided bolt</i></li><li>- <i>Reassemble A/C compressor belt</i></li></ul>
--	---	---

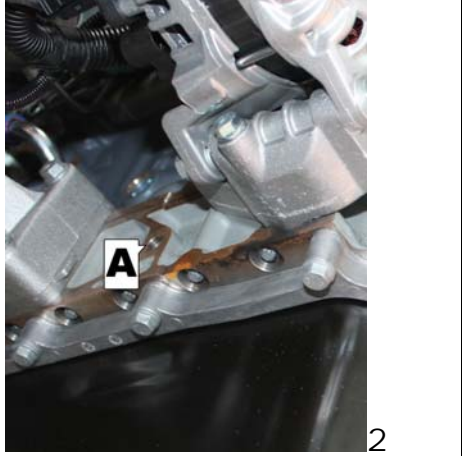
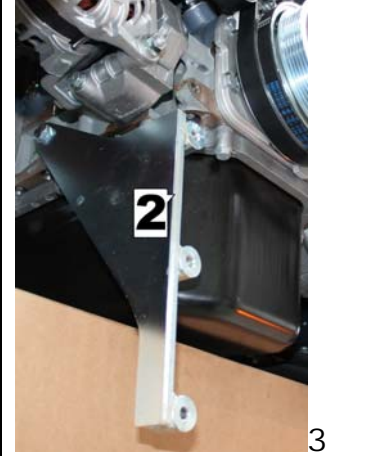
		<ul style="list-style-type: none"><li>-</li><li>- Montare la staffa 2 nel foro filettato A , senza stringere , al momento il bullone</li><li>- <i>Mount the bracket 2 into the threaded hole A , without tightening, at the time the bolt</i></li></ul>
--	---	---

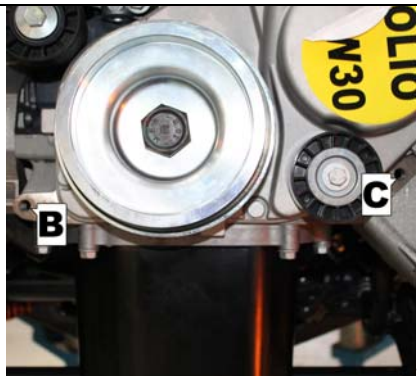

4



5



6

- Montare la staffa 1 nei fori filettati B C , fissare assieme le staffe 1 e 2 , poi stringere tutti i bulloni
- Montare innesto elettromagnetico e pompa
- Montare la cinghia
- *Mount the bracket 1 into the threaded holes B and C*
- *Fix together the brackets 1 and 2, then tighten all bolts*
- *Mount electromagnetic clutch and pump*
- *Fit the belt*

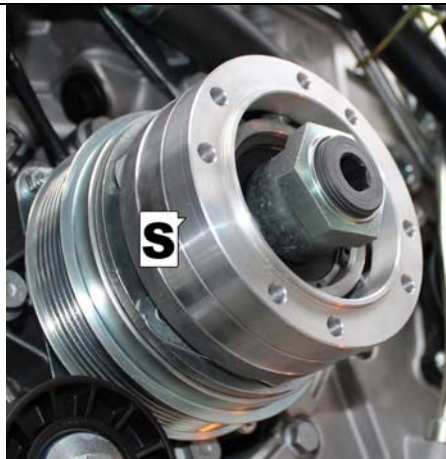

7

- Inserire il distanziale **S** nel mozzo ventola radiatore
- Rimontare la ventola , fissandola con viti fornite
- *Insert the S spacer into the hub of the radiator fan*
- *Reassemble the fan , secure with supplied screws*

- Riposizionare il gruppo radiatori
- Rimontare le viti di fissaggio radiatori
- Rimontare proiettori
- Rimontare paraurti anteriore
- Rimontare maschera frontale

- Reposition the radiator unit
- Refit the fixing screws radiators
- Reassemble projectors
- Reassemble the front bumper
- Reassemble the front mask

**TABELLA GENERALE DI SERRAGGIO BULLONI (Nm)**

**GENERAL TABLE OF TIGHTENING BOLTS (Nm)**

Qualità Quality	M6	M7	M8	M10	M12	M14	M16
8,8	10,3	17,1	25,5	50	87	138	210
10,9	14,7	24,5	35,3	70	122	194	299
12,09	17,6	28,4	42,1	85	147	235	358